

REINHOLD ENVIRONMENTAL[®]



2022 Reinhold/PCUG Round Table Presentation

Hosted by Duke Energy in the Charlotte Sheraton/Le Meridien
Hotel, Charlotte, NC on June 27-28, 2022

All presentations posted on this website are copyrighted by **REINHOLD ENVIRONMENTAL[®]** (RE). Any unauthorized attempts to print, to download, to modify, to incorporate into other presentations, to link to other websites or to obtain copies for any other uses than the training of attendees to RE Conferences is expressly prohibited unless approved in writing by RE or the original presenter. RE does not assume any liability for the accuracy or contents of any materials in this library which were presented and/or created by persons who were not employees or subcontractors of RE.

Safe and Efficient Natural Gas Plants: Dispersion Tracking from Leaks, Vents, and Exhausts

Robert Mudry, P.E.
Airflow Sciences Corporation

2022 APC Round Table
June 28, 2022

Introduction

- This session will focus on safe and efficient natural gas plant operation
- Power generation facilities
 - Natural gas plants
 - Coal-to-gas conversions
 - Dual firing units
 - Gas turbine plants
- Gas compressor stations
- Bonus if time allows: coal plants

About Airflow Sciences

- Expertise is with fluid dynamic engineering, heat transfer, thermodynamics, and combustion
- In business since 1975
- Consulting engineering services
 - CFD simulation
 - Laboratory prototype fabrication/testing
 - Wind tunnel testing
 - Field testing
- CFD Software Development
- Flow Test Equipment
- Flow Calibration Lab

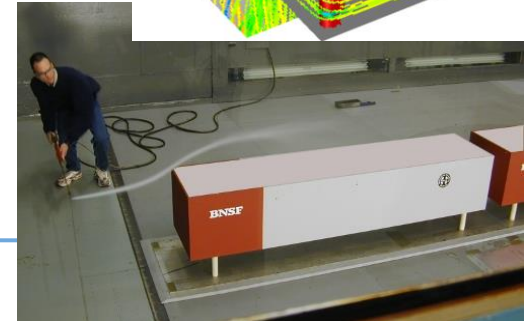
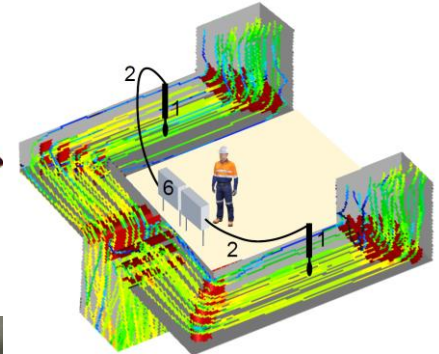
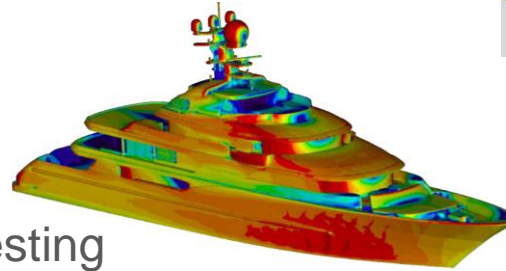
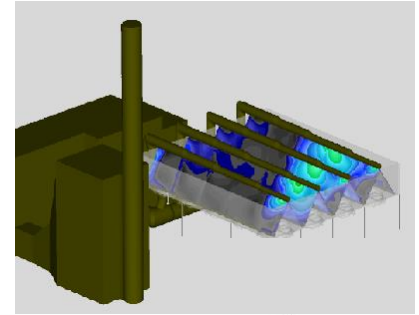

About your speaker

- Flow modeling and testing for 33 years
- Entire career at Airflow Sciences (started as summer intern)
- Rocket scientist at heart – degree in aerospace engineering
- Focus on power industry, optimization of boilers and AQCS
- Occasional work in auto, aerospace, food processing, and other industries
- Father of 4, husband of 1
- Decent volleyball coach, mediocre golfer

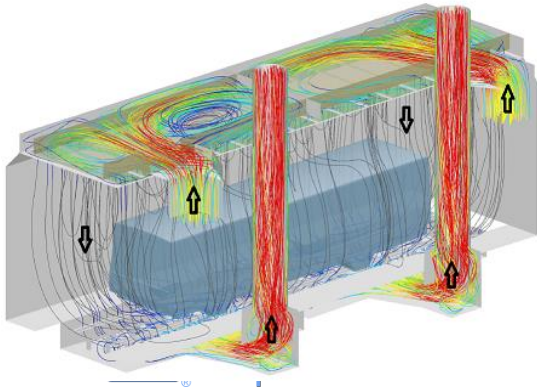

Overview

- Focus today is on plant wide, external flow considerations
 - Natural gas releases and where the plume goes
 - Is there a safety / explosion concern?
 - How to consider the risks and design the plant to avoid issues
 - Consider the influence of terrain, weather, plant layout, etc.
- Note: Air Quality Dispersion Modeling is a field of study of its own
- EPA-recommended approaches and software (i.e., AERMOD)
- Encompasses very large domains

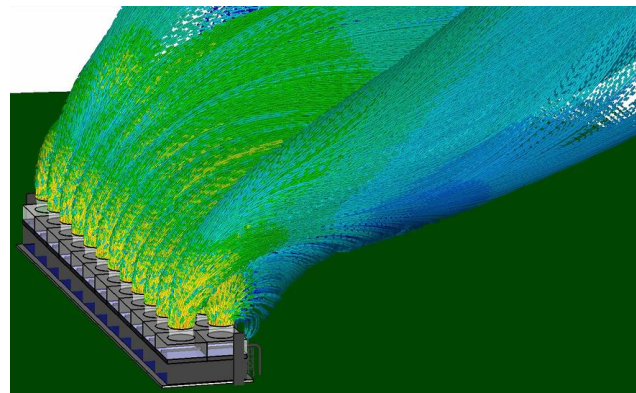

Flow Modeling Basics

- Computational Fluid Dynamics (CFD)
 - Numerical simulation of flow
 - Utilize high speed computers and sophisticated software
 - Calculate flow properties
 - Velocity
 - Pressure
 - Temperature
 - Chemical species tracking
 - Reactions and combustion
 - Particle streamlines

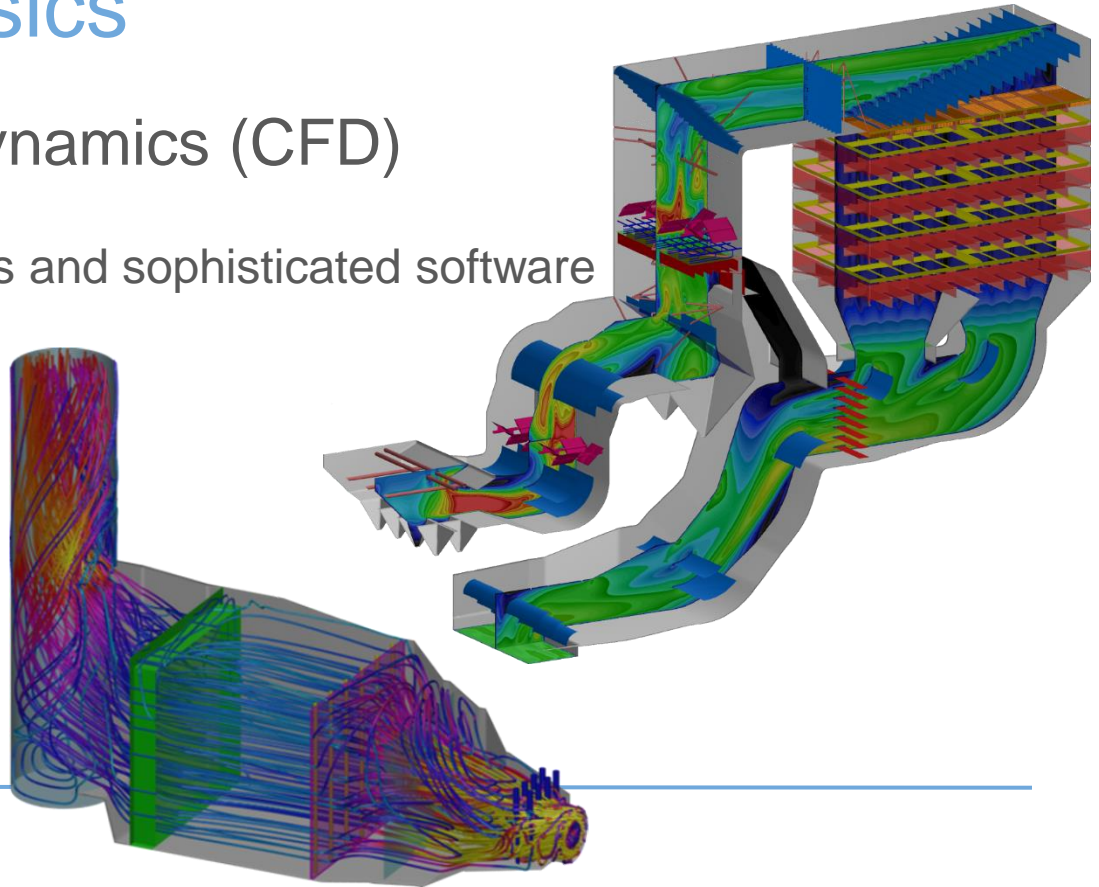

CFD External Flow Applications

- Cooling tower flow reingestion

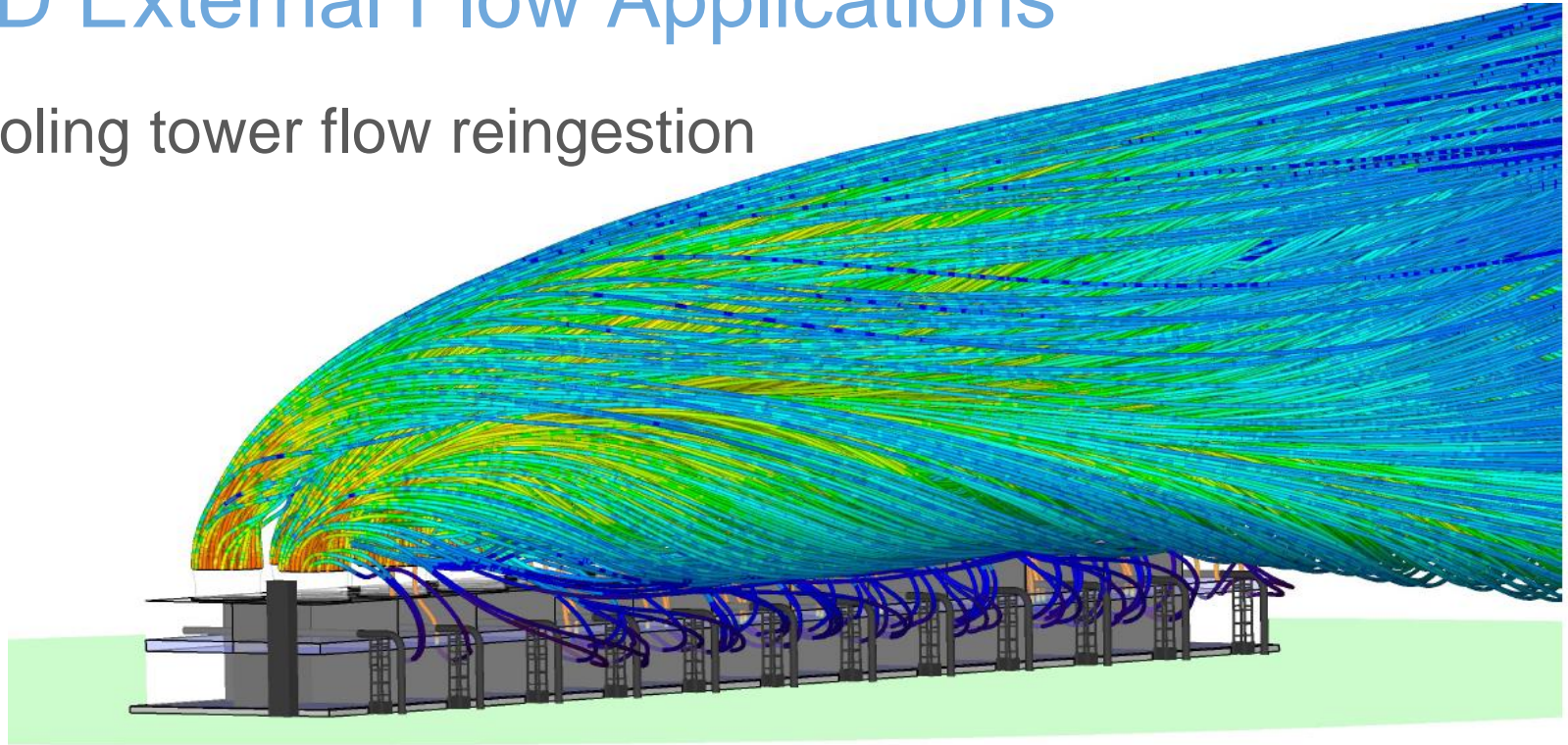

CFD External Flow Applications

- Air cooled condenser performance

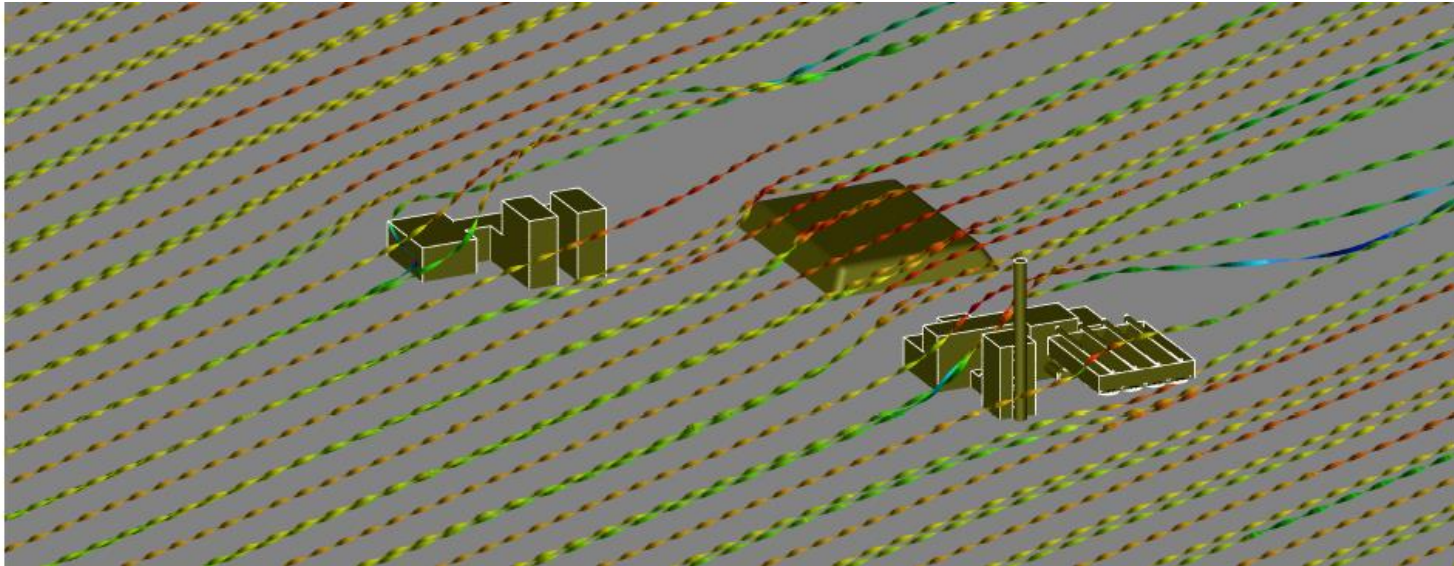

CFD External Flow Applications

- Air cooled condenser performance

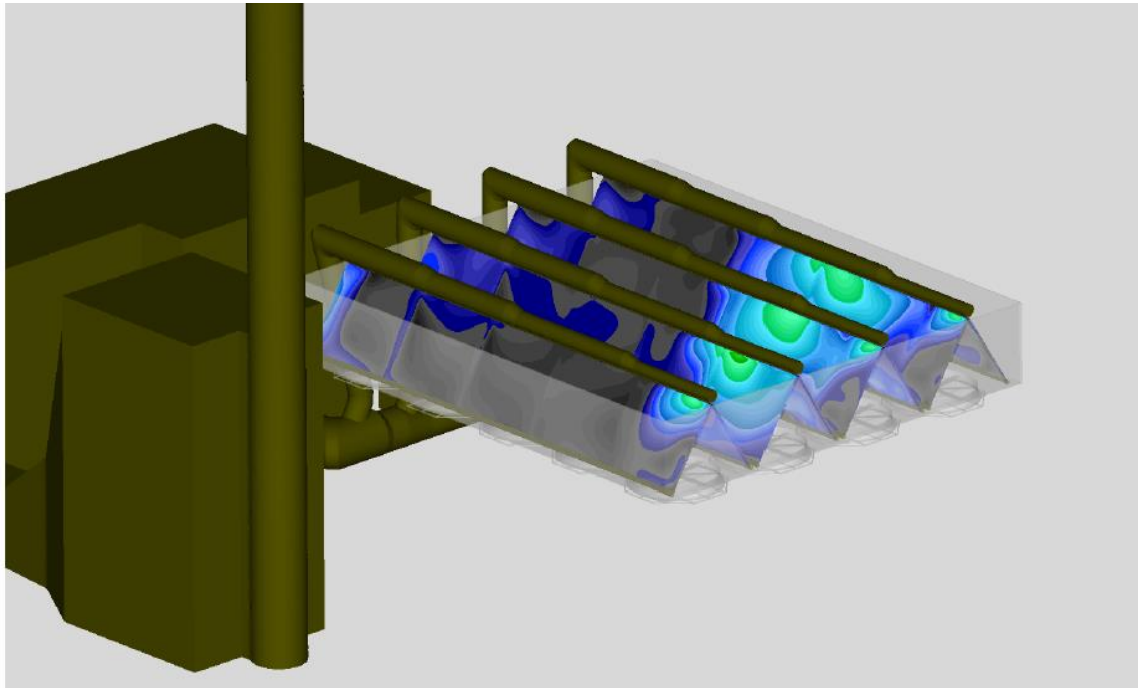

CFD External Flow Applications

- HVAC system design

- Office buildings
- Data centers
- Medical campuses

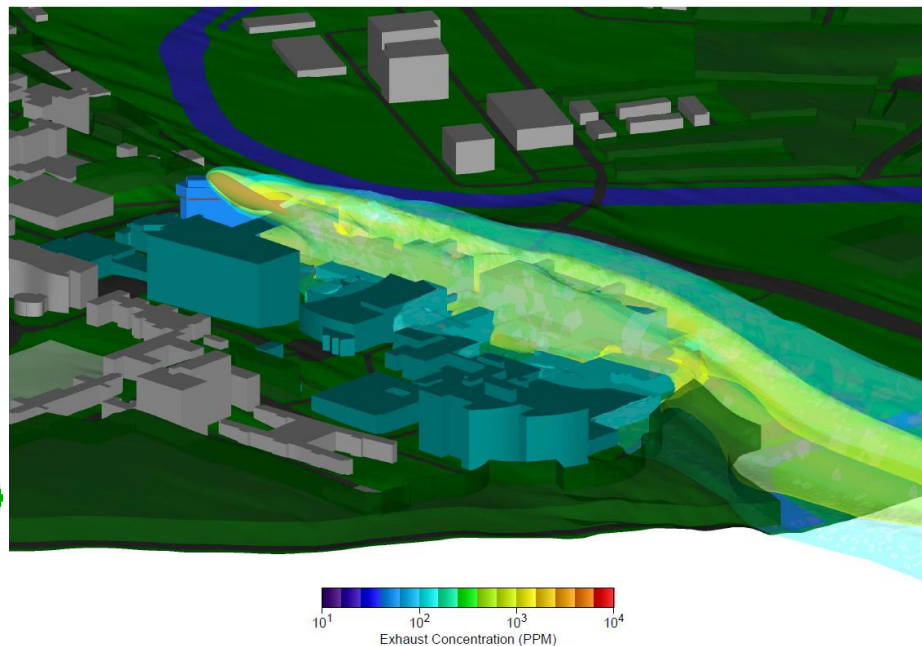
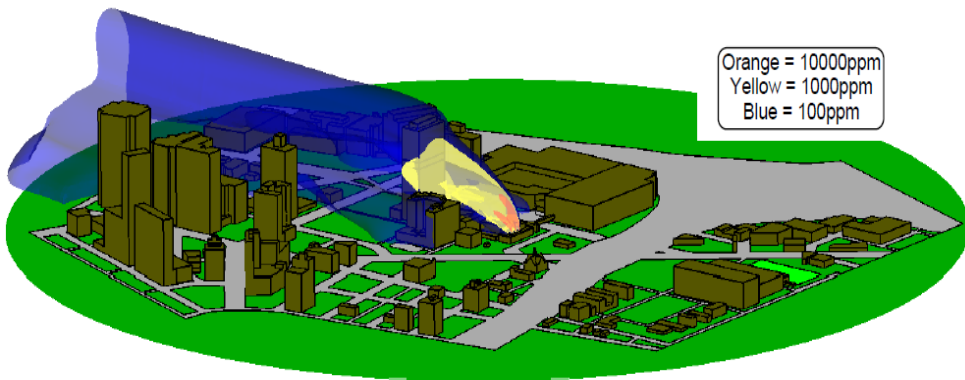

CFD Results – Medical Campus

- Research laboratory exhaust can include noxious fumes
- Where do the exhaust plumes go?
- Do dangerous concentrations exist for people nearby?
 - Parking garage
 - Lunch area
 - Walkways
 - HVAC intake vents

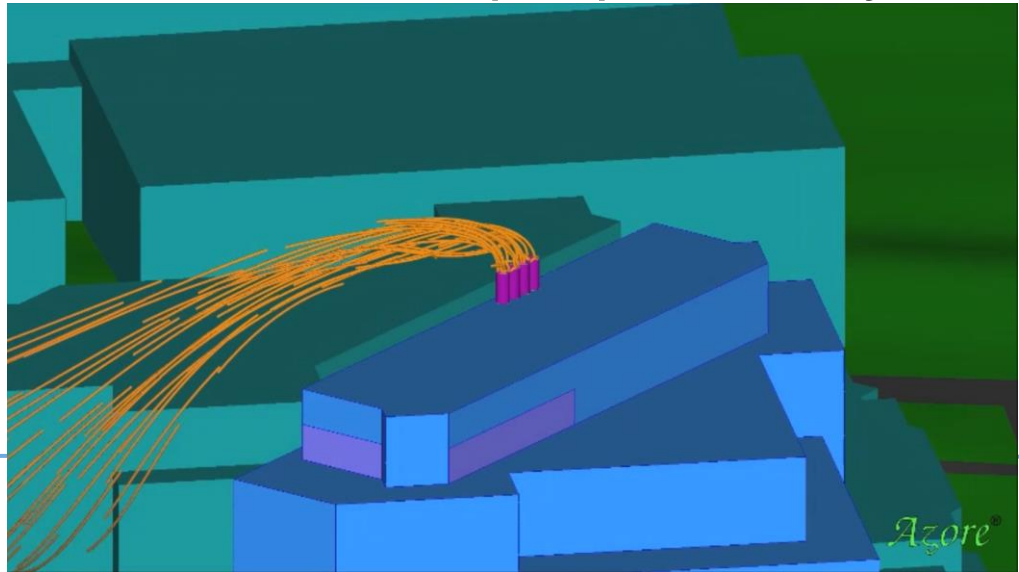

CFD Flow Animation – Medical Campus

- This video shows CFD results, tracking the exhaust from laboratory to the surrounding environment
- With a west wind, the exhaust is diluted as it is carried downstream, and only trace concentrations of harmful gas constituents such as carbon monoxide (CO) are found in populated areas of the complex.
- See YouTube link: https://youtu.be/KmINka_3aNE

CFD Modeling Set Up

- Choice of domain
- Wind conditions
- What to include
 - Buildings
 - Terrain
- Plant operating conditions
 - Normal
 - “Event”
- Do It Right = Accurate Results

CFD Modeling Process

- Choice of domain



CFD Modeling Process

- Choice of domain

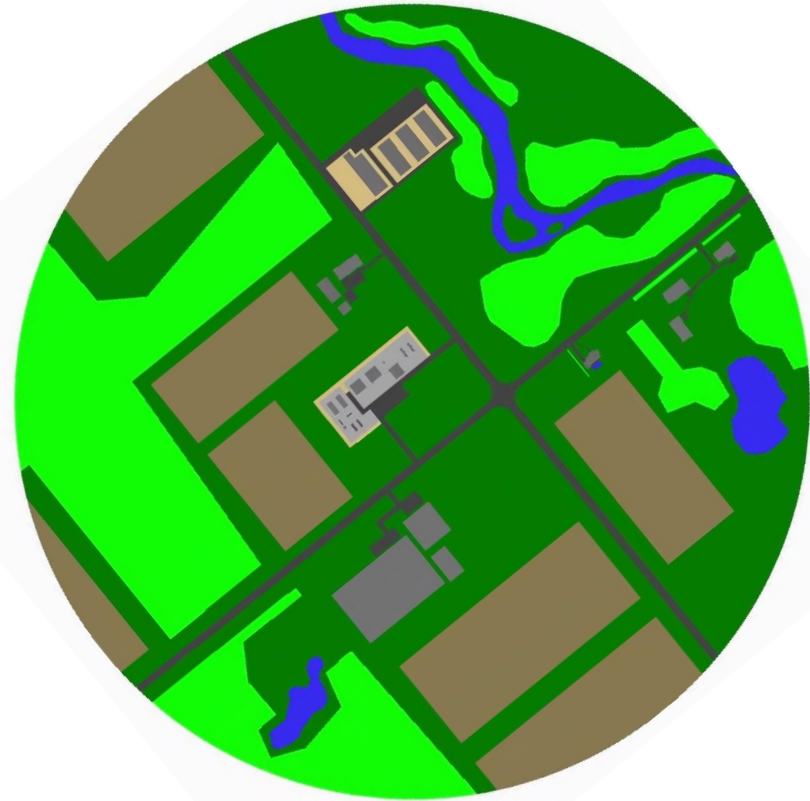
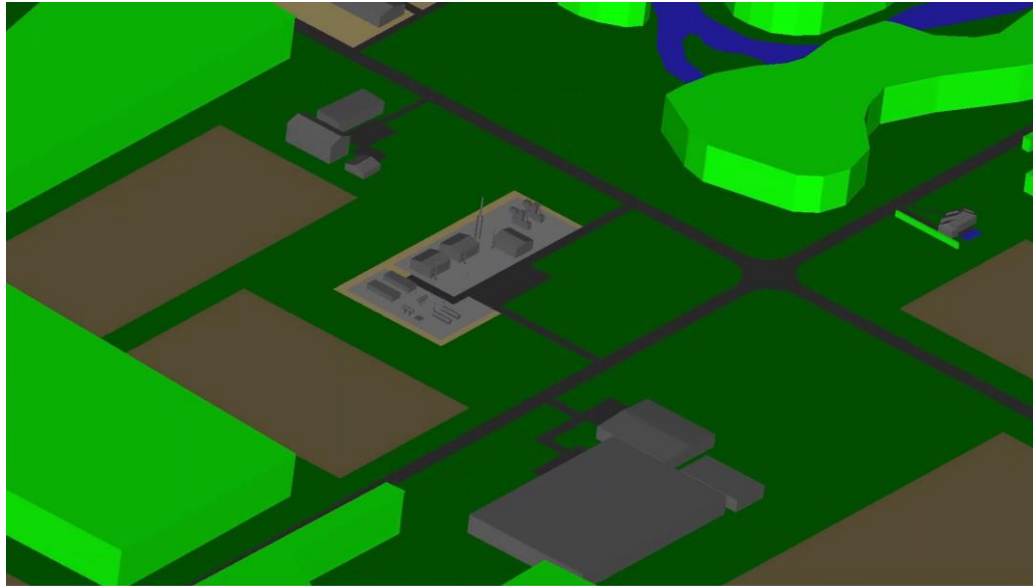

CFD Modeling Process

- Wind conditions
 - Wind Rose from local airports
 - Earth boundary layer

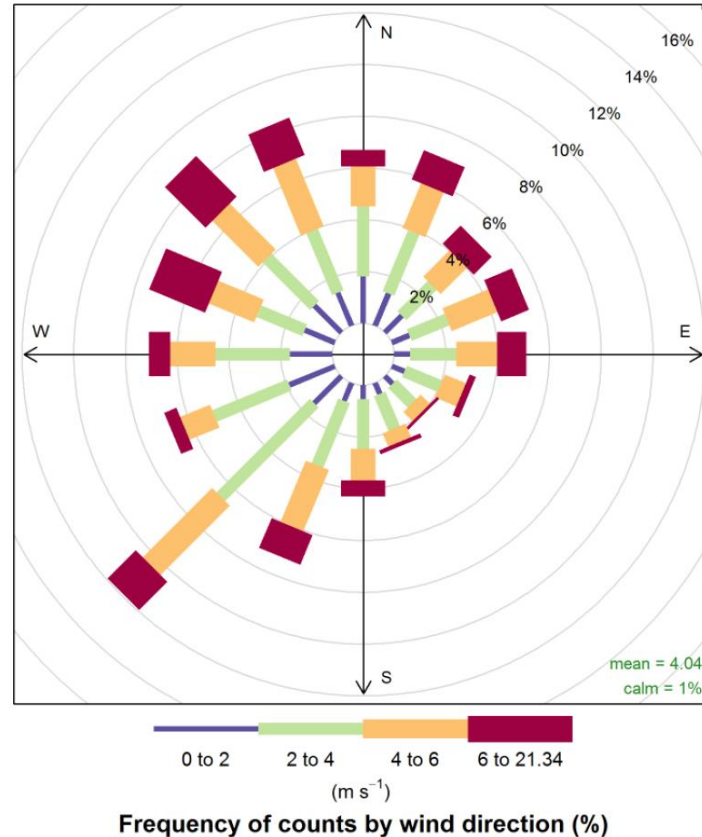

CFD Modeling Process

- Wind conditions
 - Wind Rose from local airports
 - Earth boundary layer

Wind Velocity Profile (Normalized to target velocity at 30ft elevation)

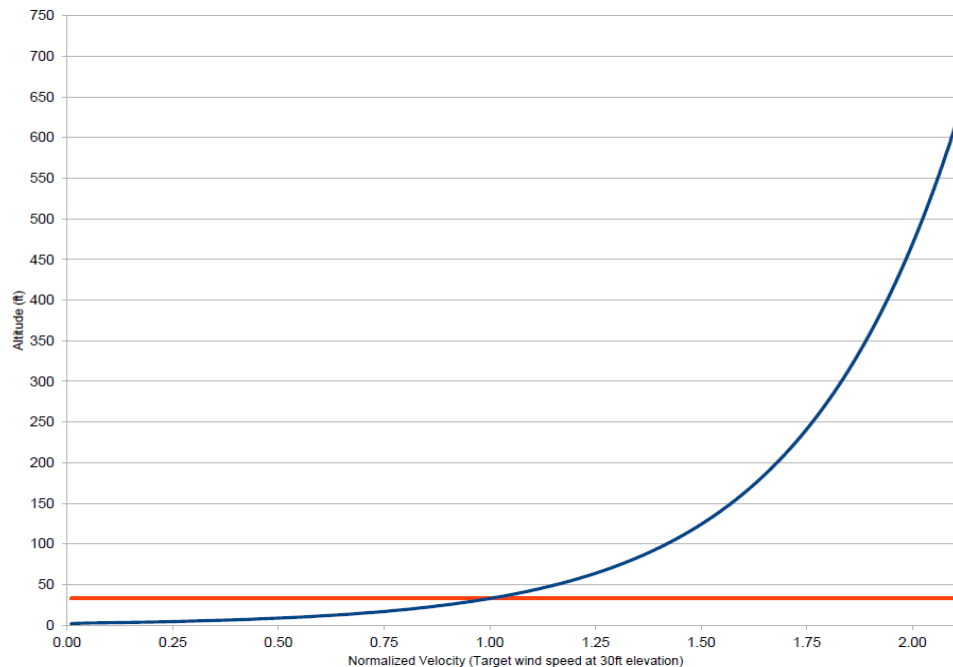

CFD Modeling Process

- What to include

- Buildings
- Terrain

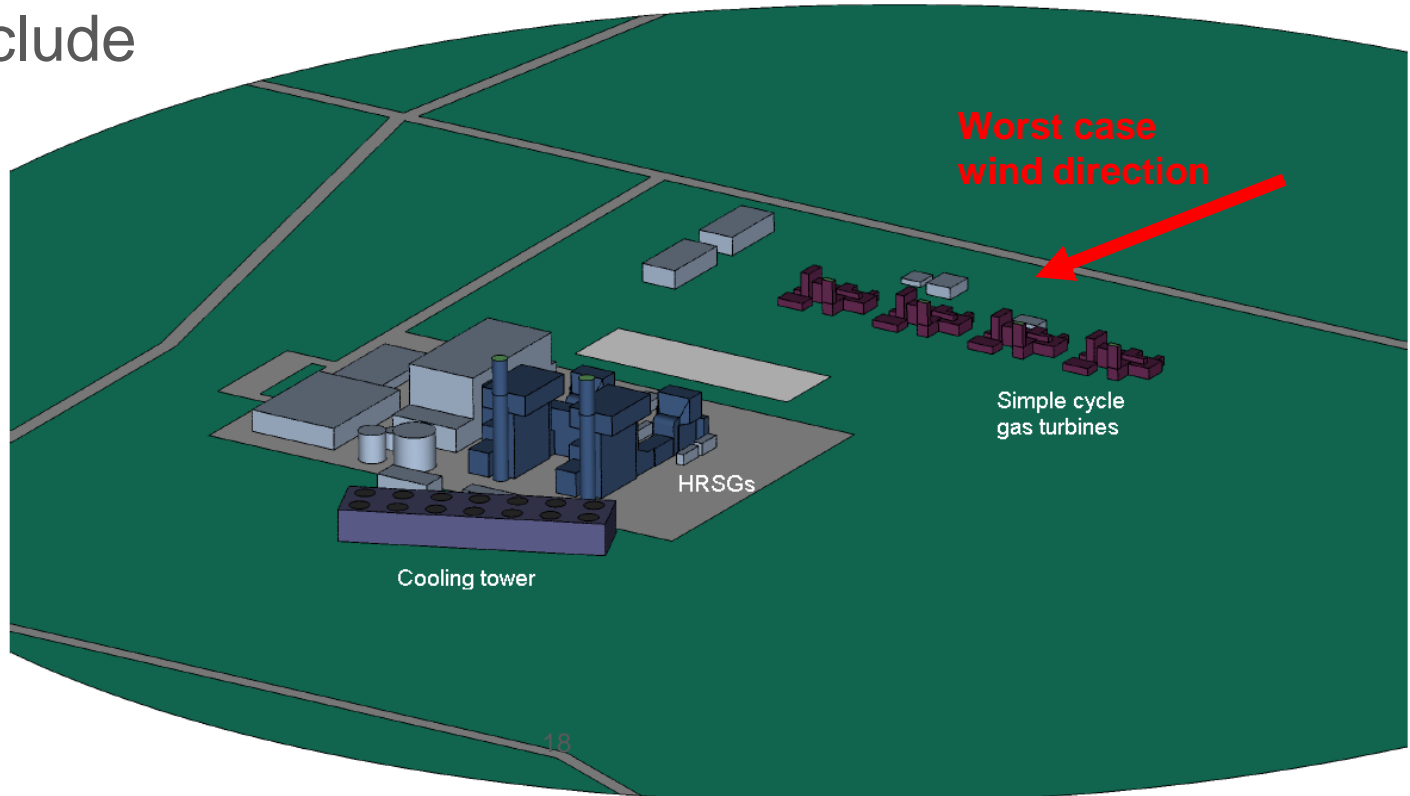

CFD Modeling Process

- Plant operating conditions
 - Normal
 - “Event”

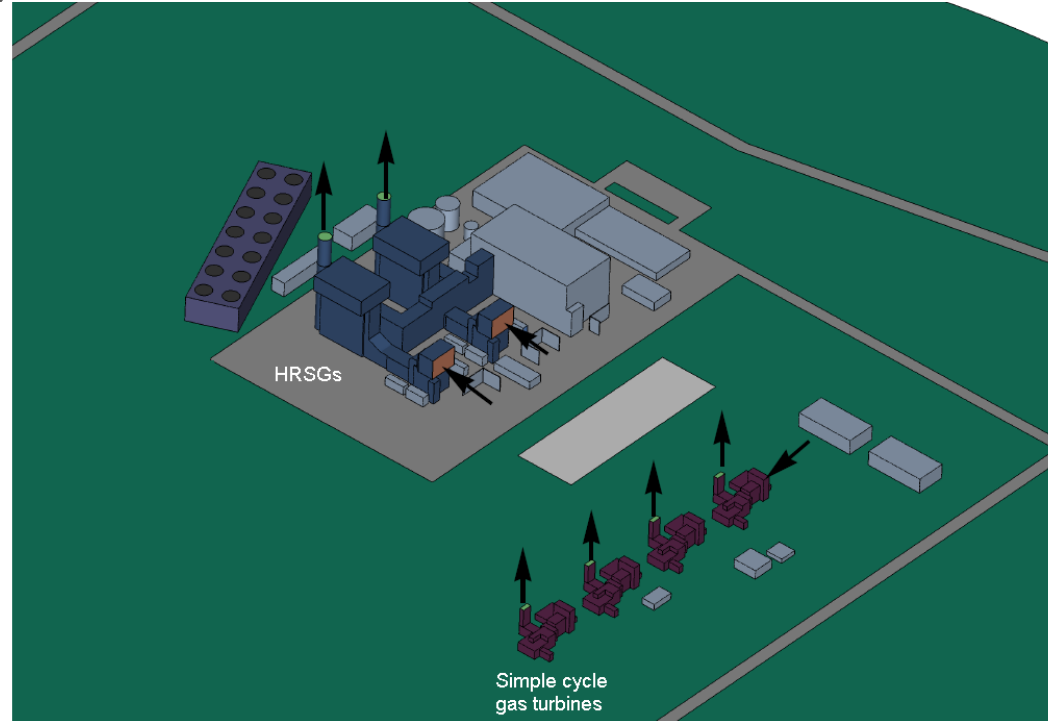

CFD Modeling Process

- Worst case wind direction

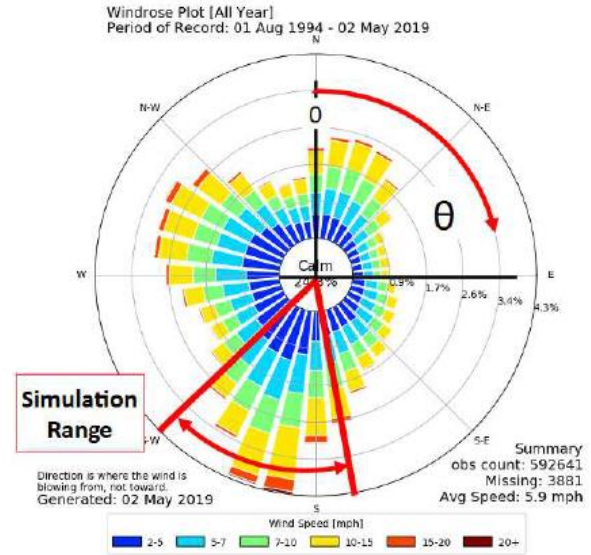
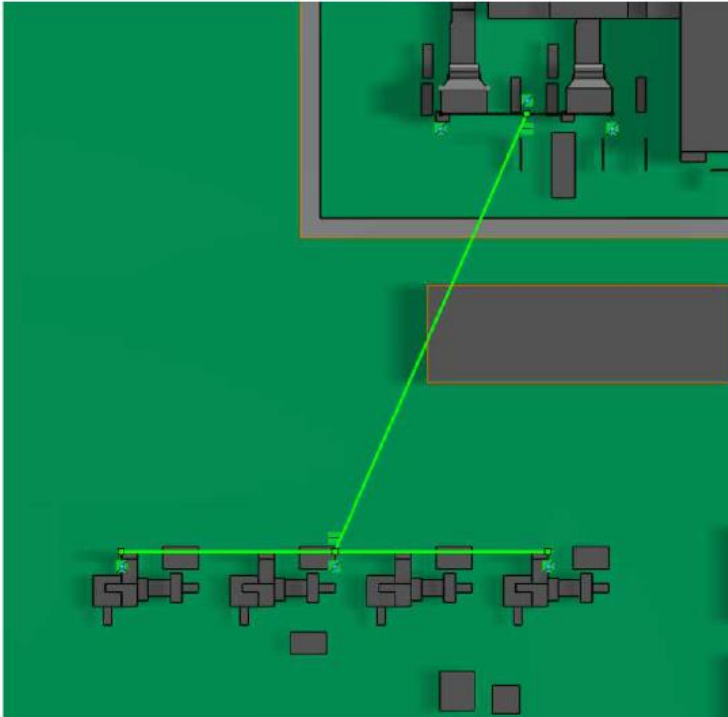

$$\theta = 204^{\circ}$$

CFD Modeling Process

- Initial CFD cases to run

Units Operating Conditions

	Parameter	Units	
Simple cycle gas turbines	Inlet Flow Rate	lb/s	600
	Exhaust Flow Rate	lb/s	610
	Exhaust Temp	F	1000
	Exhaust NOx Conc	ppm	6.8
	Exhaust CO Conc	ppm	11.5
HRSGs	Inlet Flow Rate	lb/s	5677
	Exhaust Flow Rate	lb/s	5808
	Exhaust Temp	F	162

CFD Run Matrix

Run	Season	Ambient Temp (F)	Wind Speed (mph)	Wind Direction (deg)
1	Summer	80	6	204
2	Summer	80	20	204
3	Winter	30	20	204

- Summer, average wind speed, worst angle
- Summer, highest wind speed, worst angle
- Winter, highest wind speed, worst angle

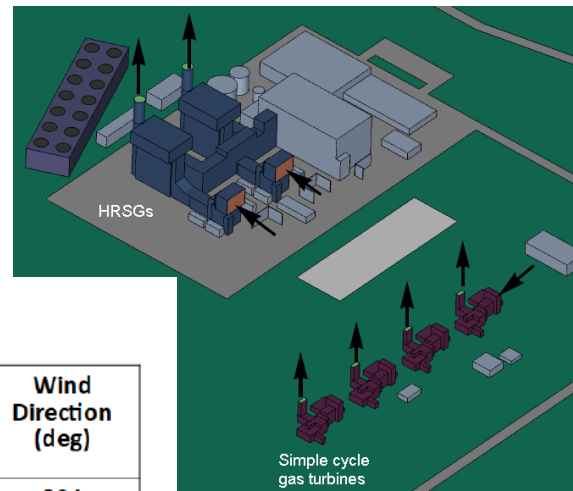

CFD Modeling Process

- Run the model
 - What software?
 - What hardware?
- Analyze results
 - Static images
 - Animations
 - Flow statistics
- Iterative design optimization
 - “What if?” scenarios
 - Examine geometry and operating conditions

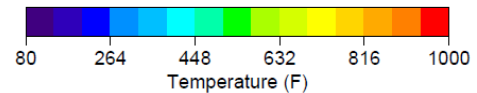
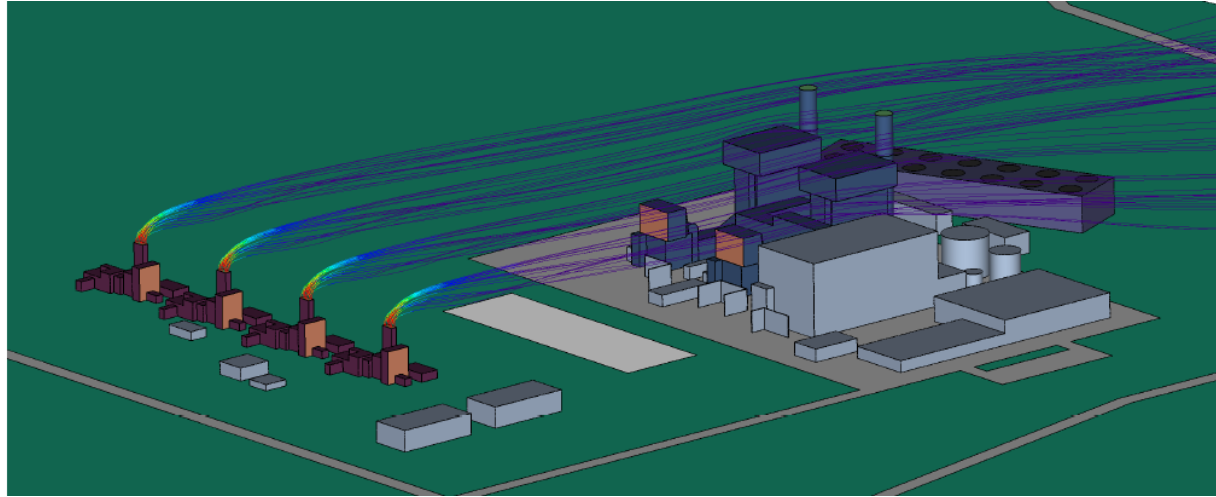

Case Studies

- Natural Gas Plants

- Coal to gas conversion – external flow – venting event
- Coal to gas conversion – internal flow – building leak
- Peakers near HRSGs – external flow – exhaust intake by HRSGs

- Compressor Station

- Vent stack release – external flow – where does the plume go?

- Bonus: Coal plant

- Wet stack influence on the neighborhood

Case 1 – Coal to Gas Conversion

- External flow model to examine N.G. venting system design

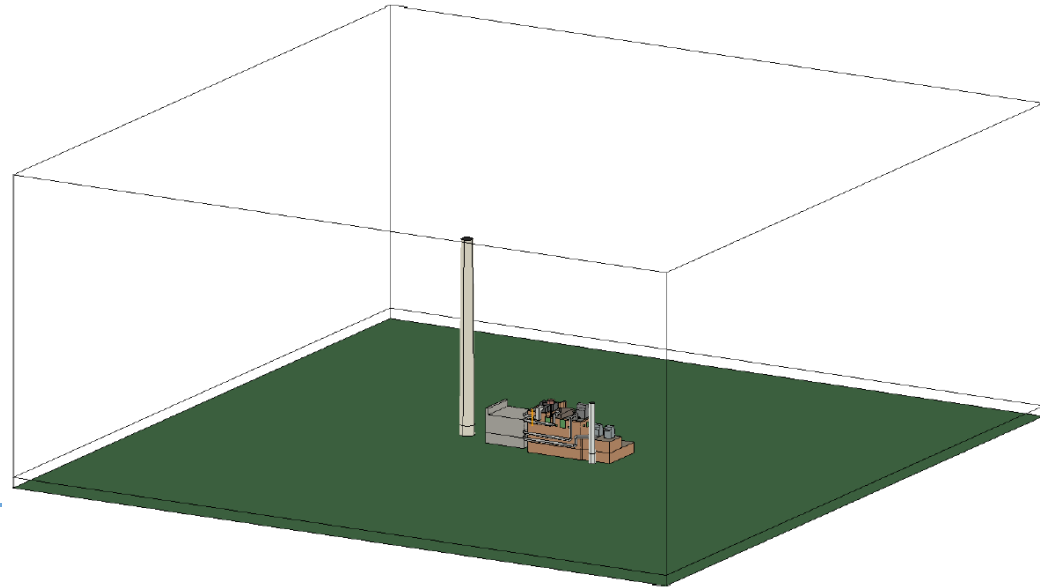

Case 1 – Coal to Gas Conversion

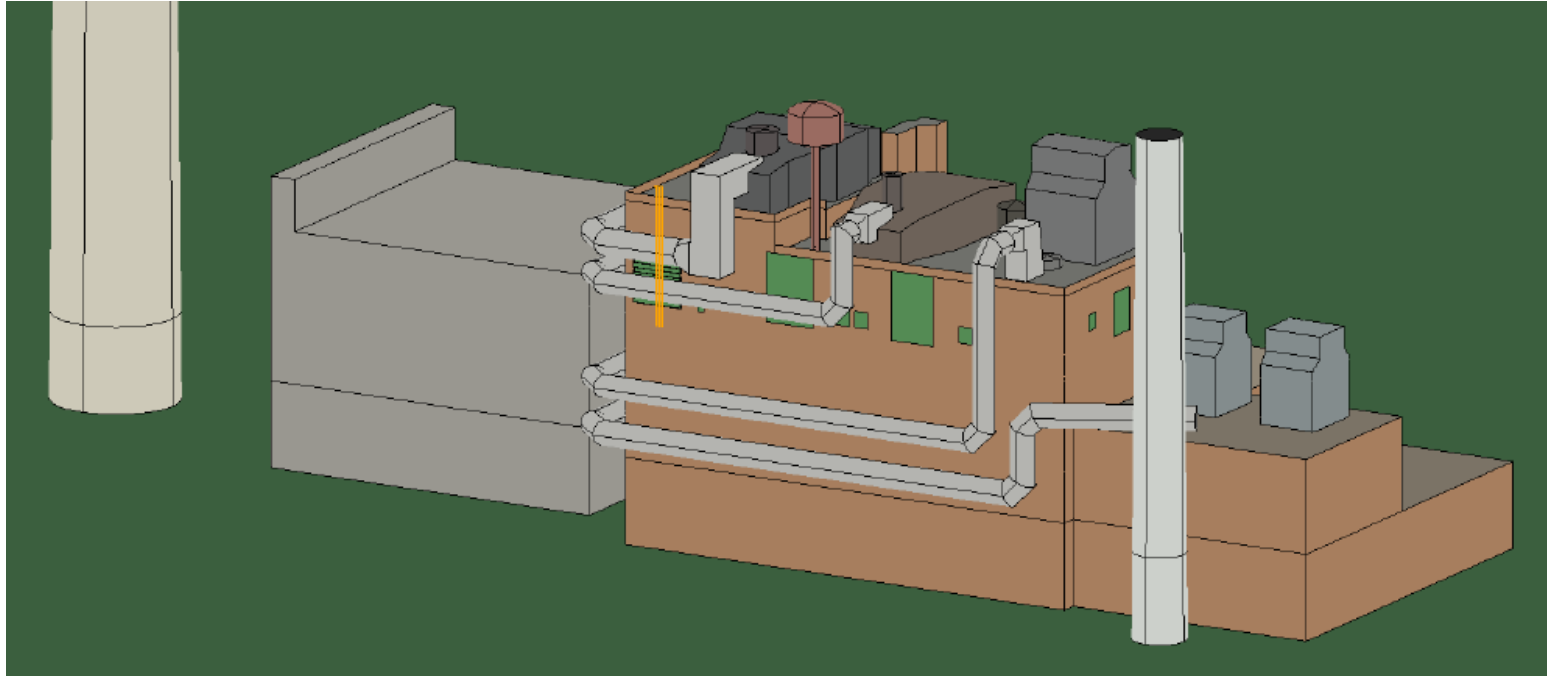

Case 1 – Coal to Gas Conversion

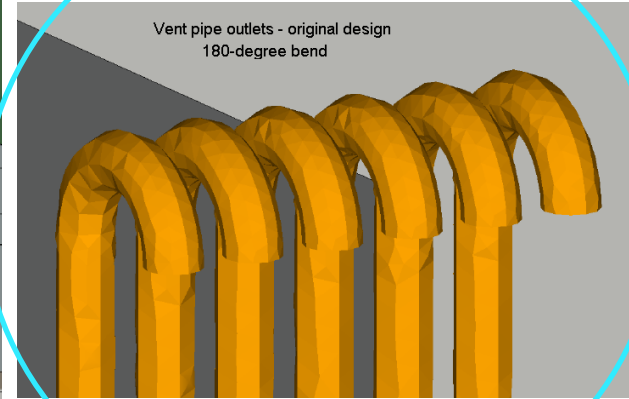
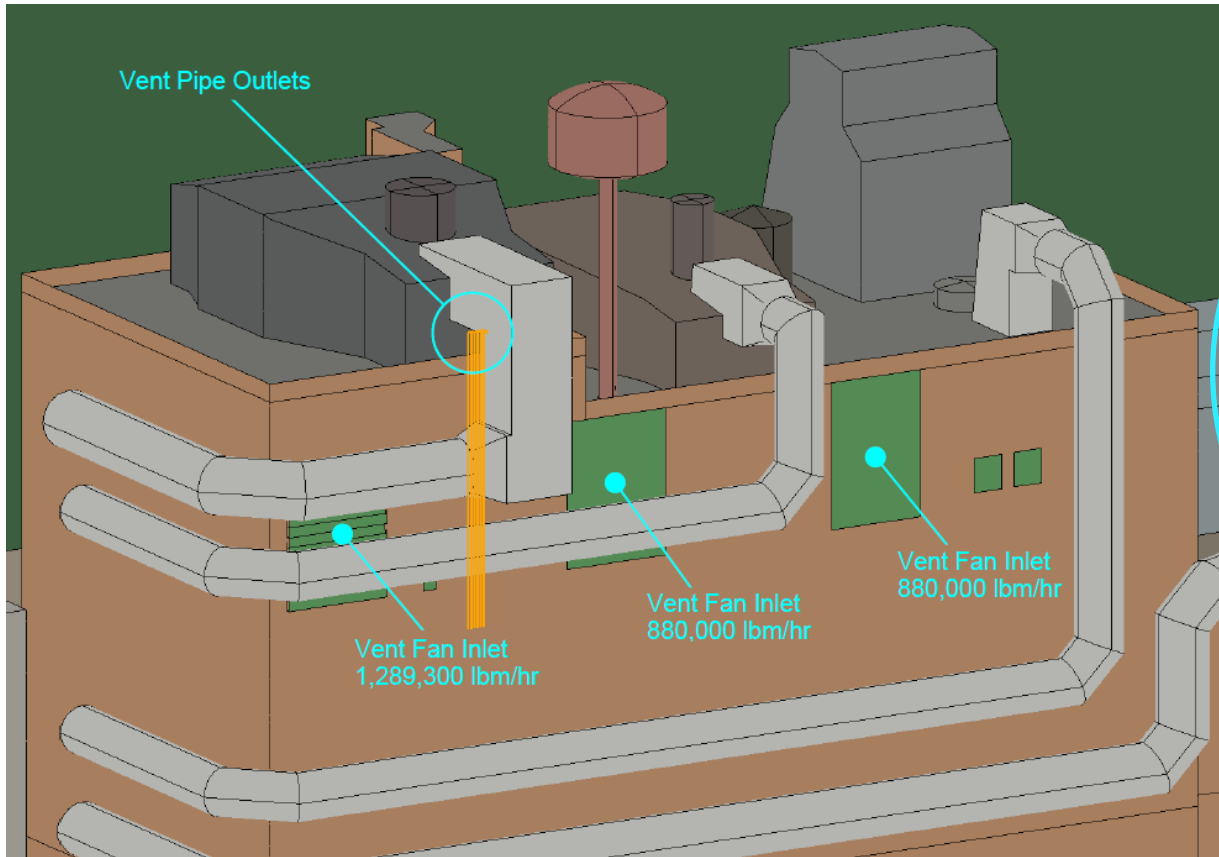

Velocity Magnitude - (3) Wind From W @ 5 MPH

Imposed Velocity Profile

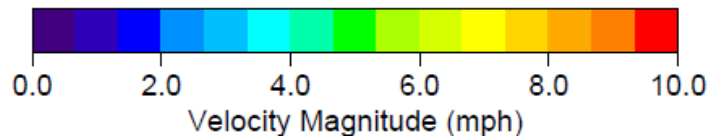
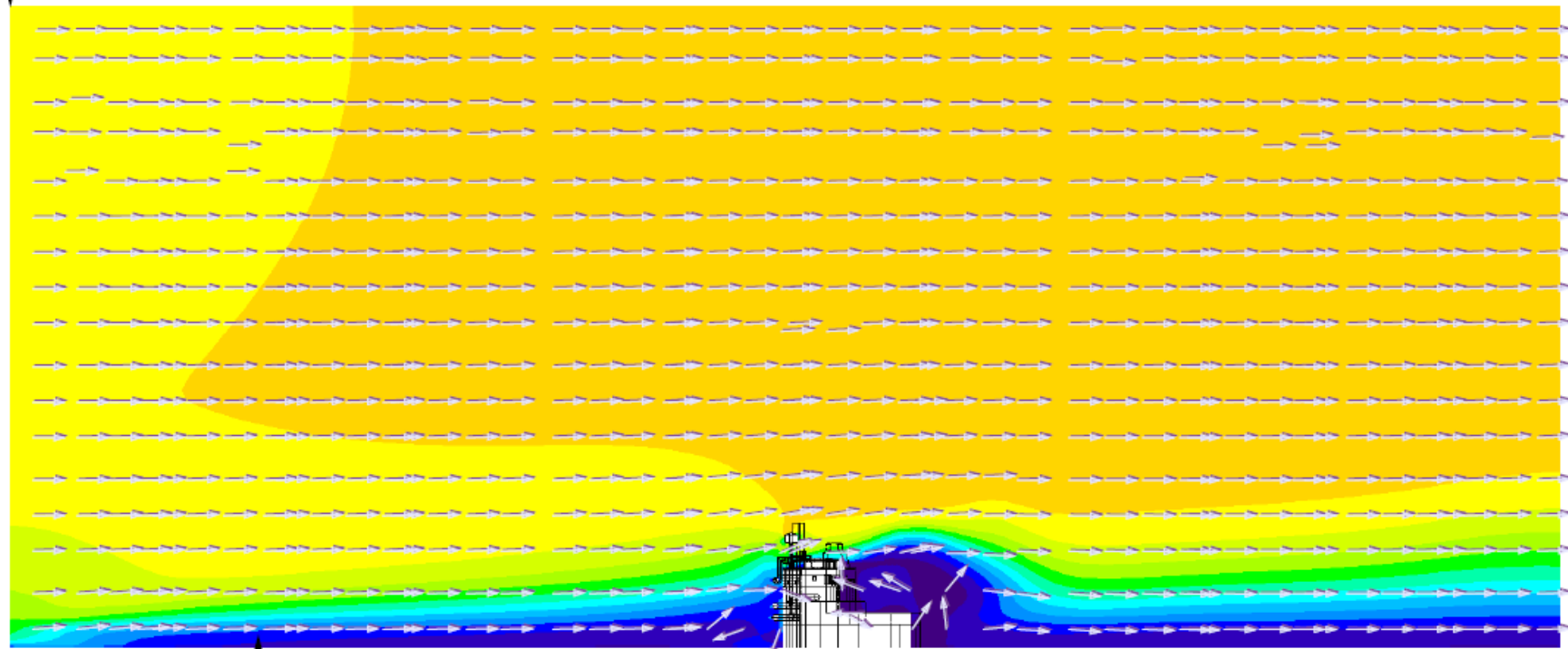

Original design vents
CH₄ concentration

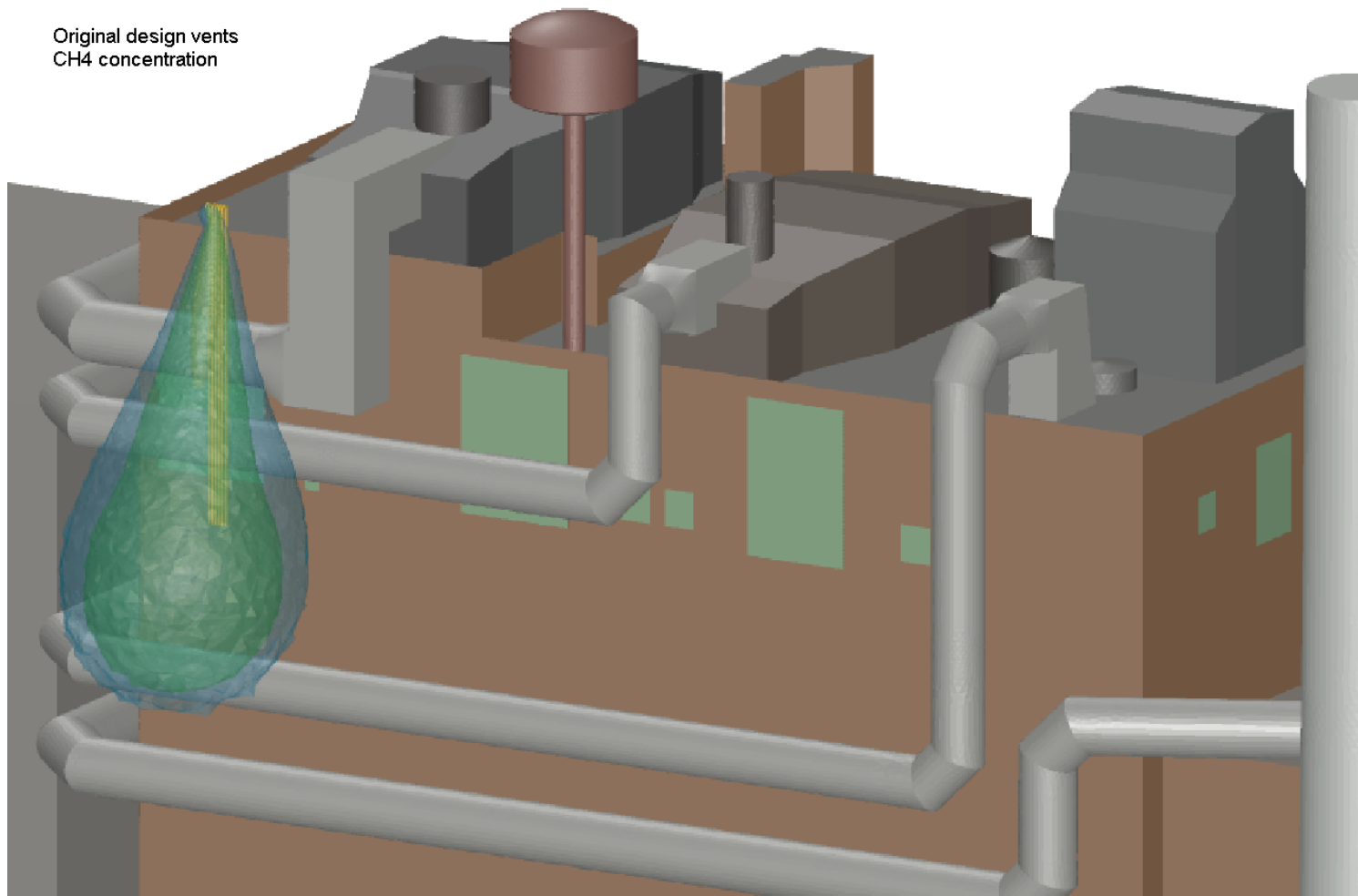

CFD Flow Animation – Coal to Gas Conversion

- This video shows a time-dependent CFD model of the natural gas venting event over ~12 seconds
- The gas concentration bubble grows over time, showing the potential for dangerous concentrations near the building intake vents
- The model was used to redesign the vent pipes to reduce potential for hazardous conditions
- See YouTube link: <https://youtu.be/E3hN4VXO6F0>

Case 1 – Coal to Gas Conversion

Vent pipe outlets - final design
45-degree angle pipes (orange)
with extension sleeve (pink)

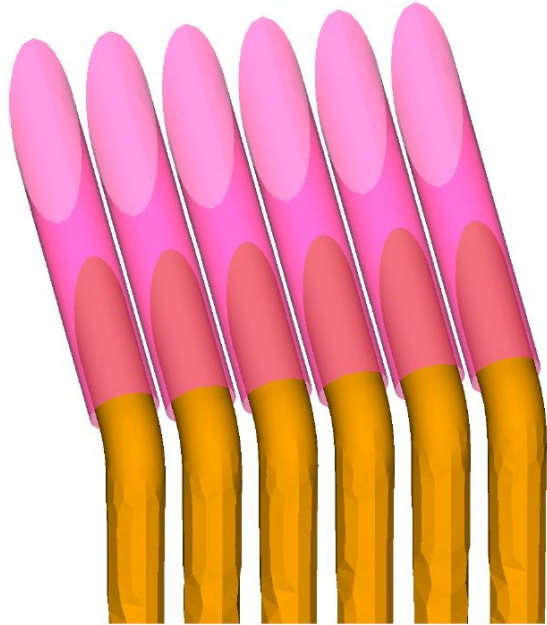

Final design vents
CH4 concentration

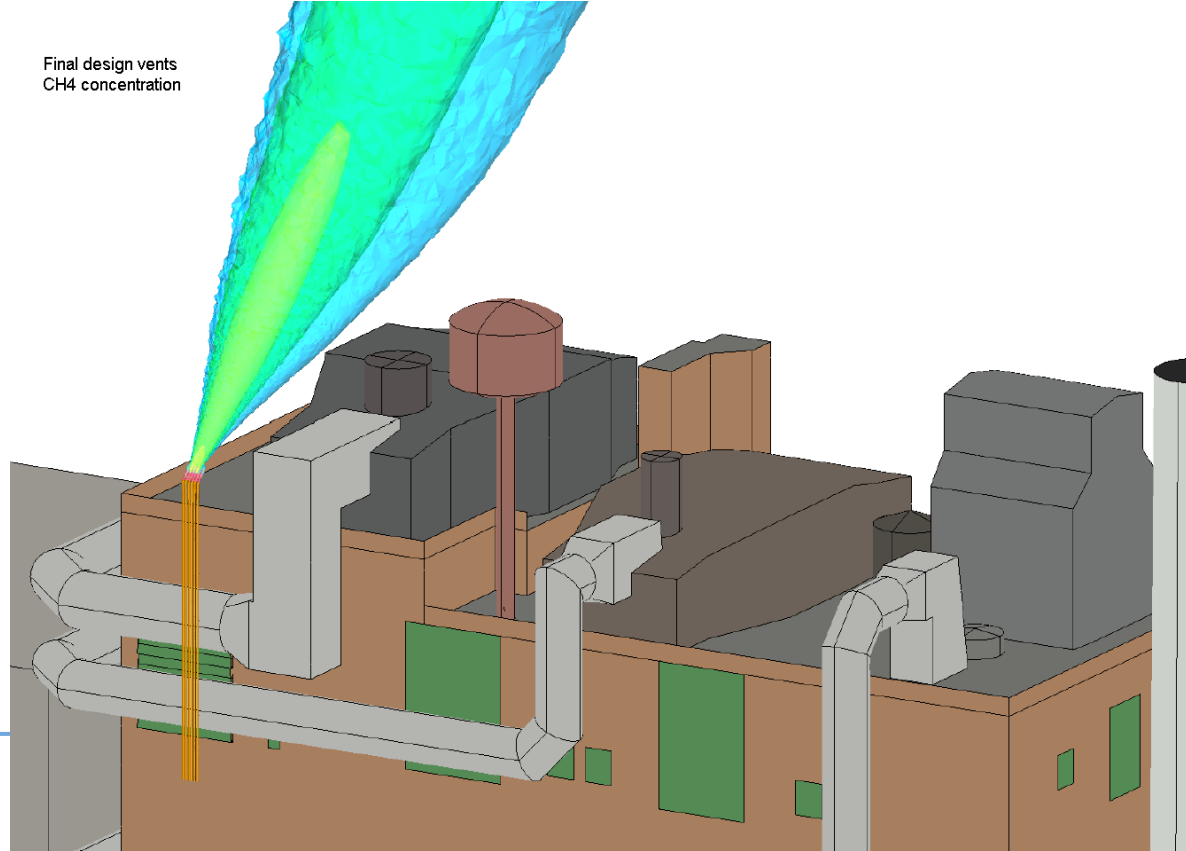

Case 2 – Coal to Gas Conversion

- Coal plant conversion to gas raises concerns over boiler building ventilation capacity
 - Coal plant design features concrete floors at burner decks which can limit ventilation in the event of a leak
 - Plant HVAC system capacity may need updates
 - Where to put monitors and alarms?



Case 2 – Coal to Gas Conversion

- CFD modeling of potential leaks, monitoring, and ventilation options can be part of the design solution

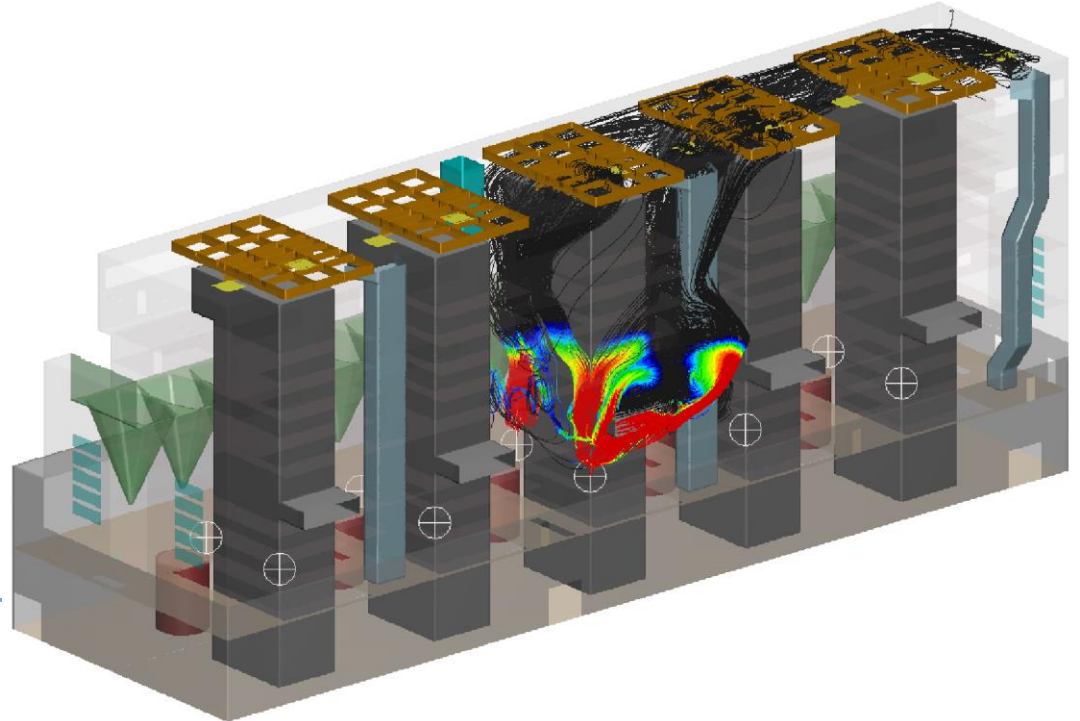

CFD Flow Animation – Coal to Gas Conversion

- This video shows a time-dependent CFD model of the boiler building, tracking a natural gas leak over ~13 minutes
- The leak grows initially, with 2 ventilation fans running
- After ~4 minutes, the leak is detected by monitors and additional ventilation fans turn on to evacuate the gas
- See YouTube link: <https://youtu.be/Y2D4hwZDkKs>

Case 3 – Peakers near HRSGs

- How does the exhaust from one plant affect performance of a neighboring plant?
 - Simple cycle gas turbines have high outlet temperature exhaust
 - Will this result in higher inlet temperatures for nearby HRSGs, degrading turbine performance?
 - What about NO_x and CO emissions? Will there be a danger for workers?

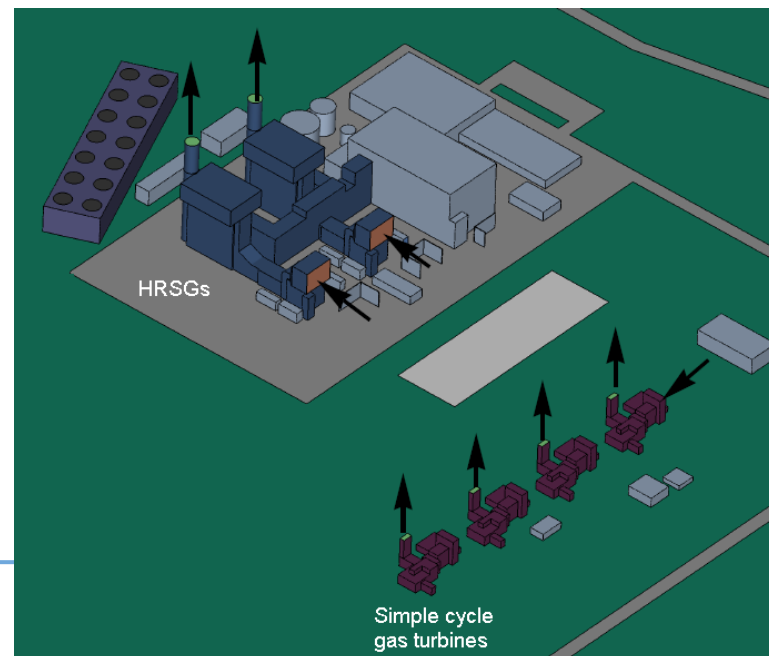

Case 3 – Peakers near HRSGs

6 MPH wind

20 MPH wind

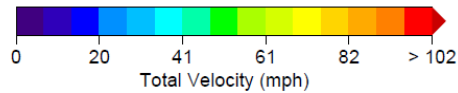
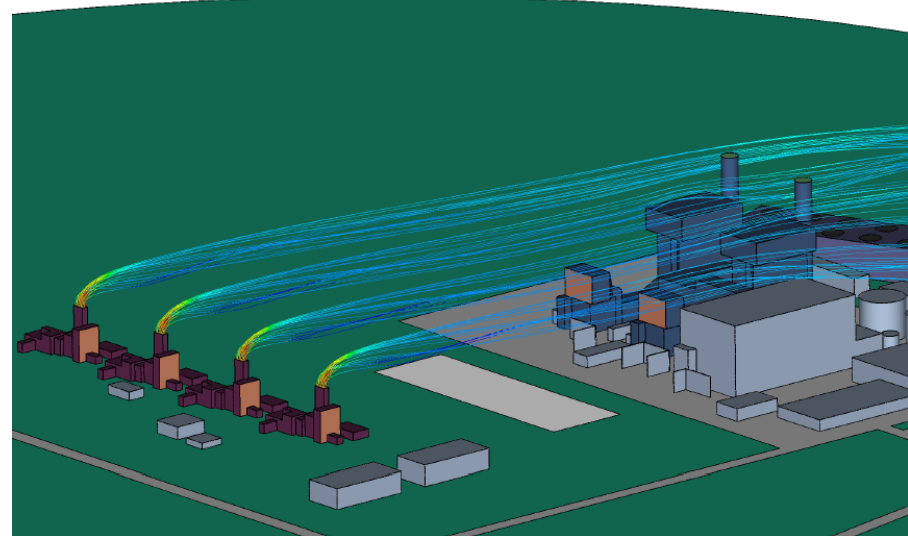
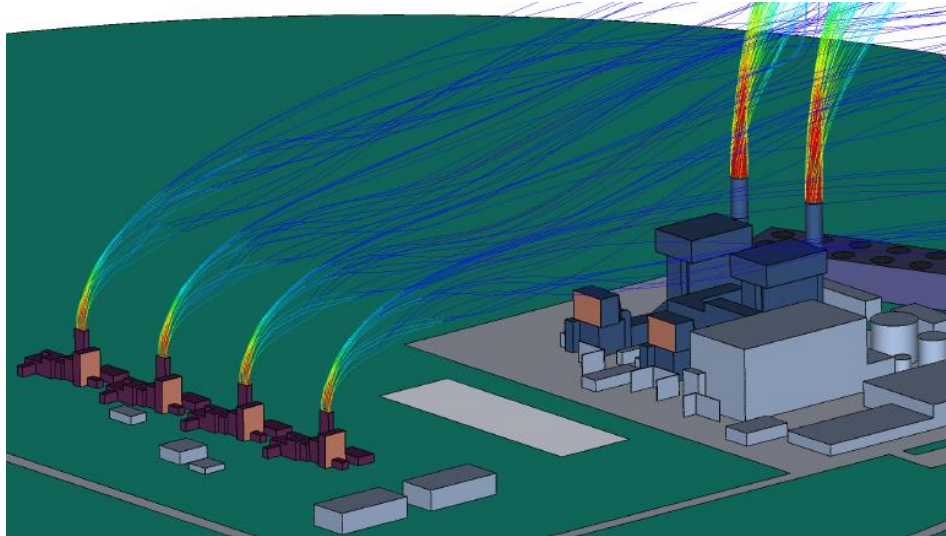

Case 3 – Peakers near HRSGs

6 MPH wind

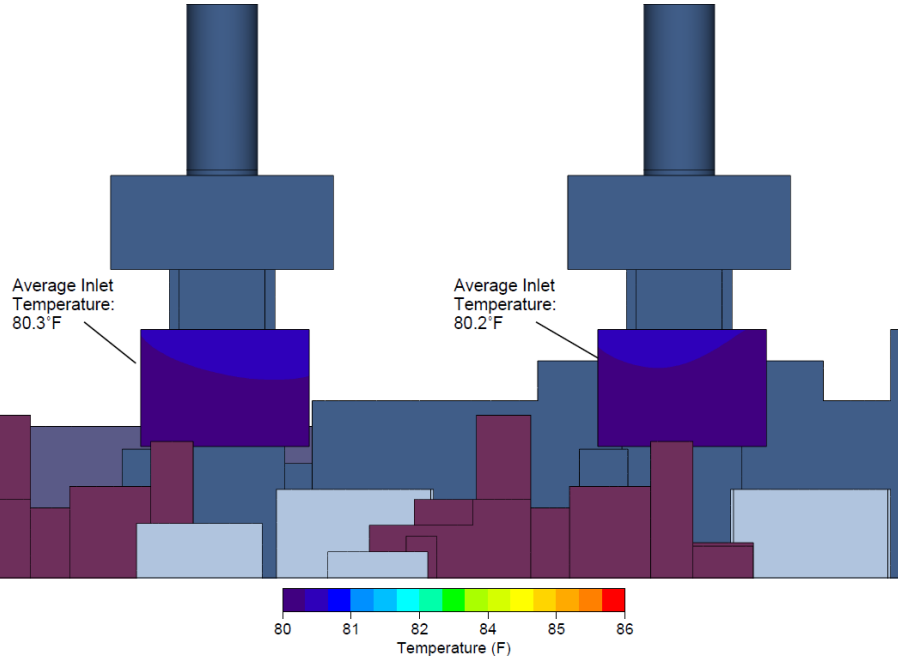

20 MPH wind

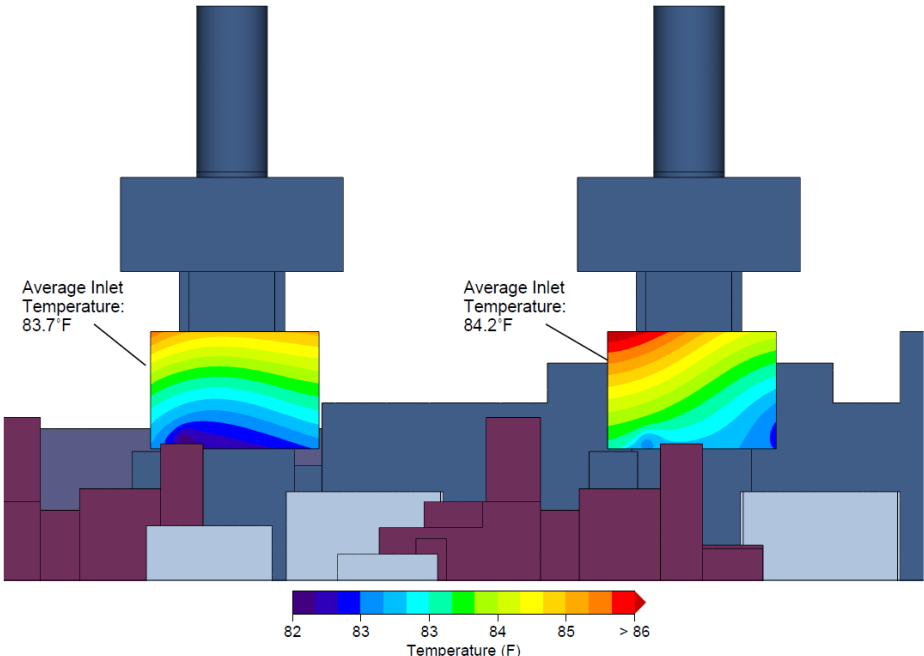

Case 4 – Compressor Station

- How does the exhaust from a gas vent stack affect safety of a nearby equipment?
 - Are there any nearby ignition sources?
 - What is the gas concentration near an ignition source?
 - Where are workers and/or the public located with respect to the stack plume?
 - Do certain wind/weather conditions pose more risk?
 - What can be done to vent stack design to improve safety?
 - What if a nearby operating gas turbine ingests gas from a vent stack?

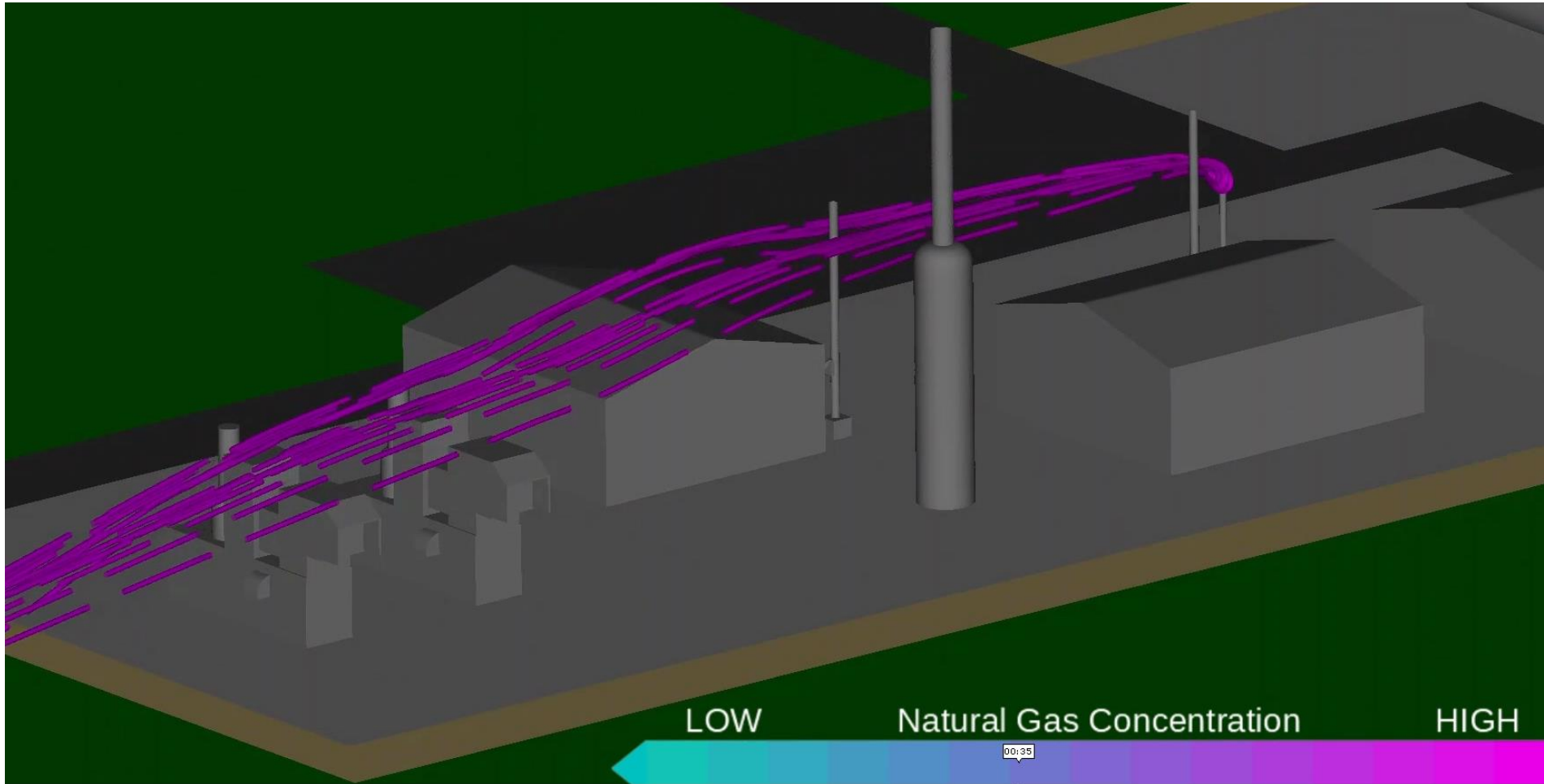

CFD Flow Animation – Compressor Station

- This video shows CFD results of the natural gas vent stack, and how the plume is diluted and carried by the wind
- Though no explosive concentrations are present at nearby buildings and the gas turbine intakes, there is a potential for trace amounts of natural gas to be ingested by the downwind gas turbines.
- A solution was found that modified the vent stacks to minimize the potential for operational issues
- See YouTube link: <https://youtu.be/K1BS8Y--Mc0>

Case 5 – Coal Fired Plant

- How does the exhaust from a wet stack affect the neighborhood?
 - Stay tuned
 - Airflow Sciences' Summer 2022 Newsletter will be out soon!

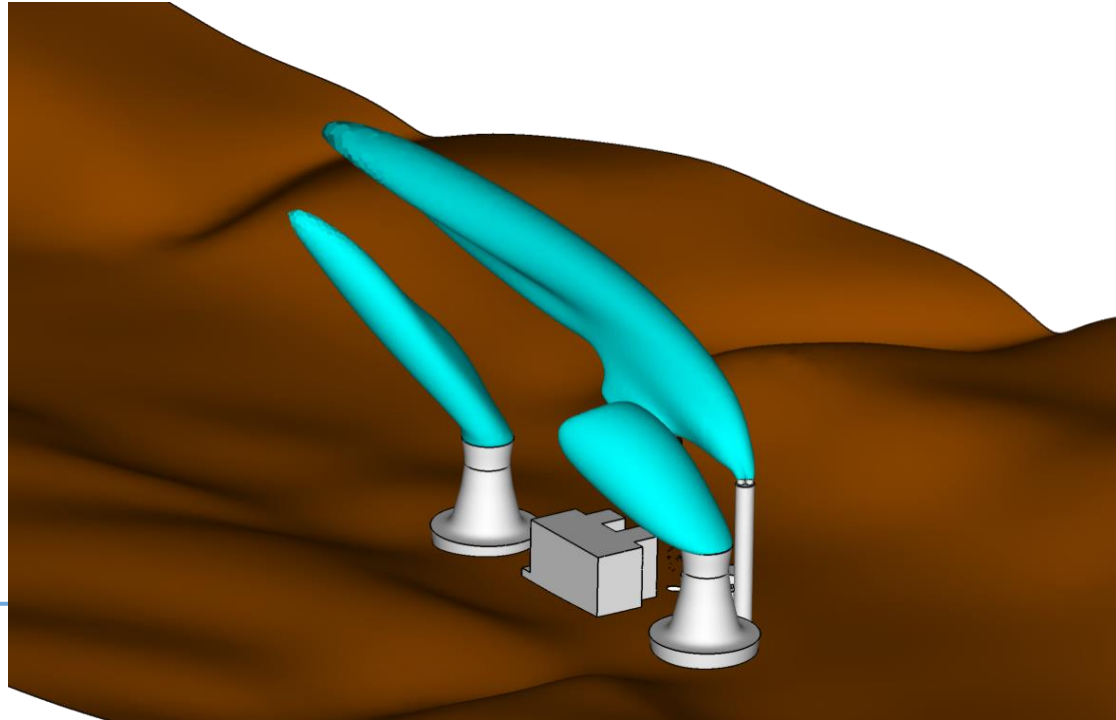

Summary

- There are many external and internal flow parameters that affect gas plant safety and efficiency
- CFD modeling is an effective tool to understand potential issues and risks over a range of operating scenarios and weather conditions
- Cost-effective design improvements are possible to existing systems and new construction

Questions & Contact Information

Robert Mudry, P.E.

President

734-525-0300 x202

rmudry@airflowsciences.com

www.airflowsciences.com

www.azorecfd.com